

DATE:	12/07/2004	REVISIONS:		STANDARD DETAIL	LEXINGTON COUNTY JOINT MUNICIPAL WATER AND SEWER COMMISSION
SCALE:	NTS			TYPICAL FENCE CORNER	FILE NO. SP006K

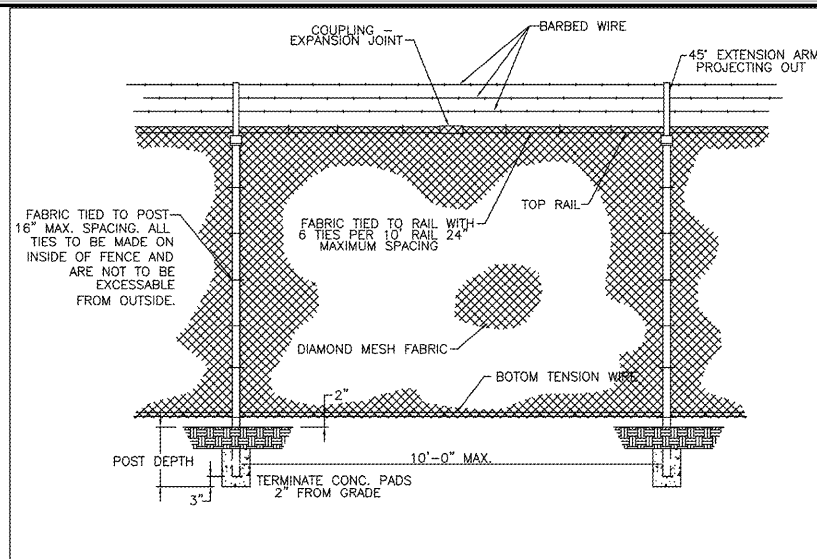

DATE:	12/7/2004	REVISIONS:		STANDARD DETAIL	LEXINGTON COUNTY JOINT MUNICIPAL WATER AND SEWER COMMISSION
SCALE:	NTS			TYPICAL FENCE LINE SPAN	FILE NO. SP006L

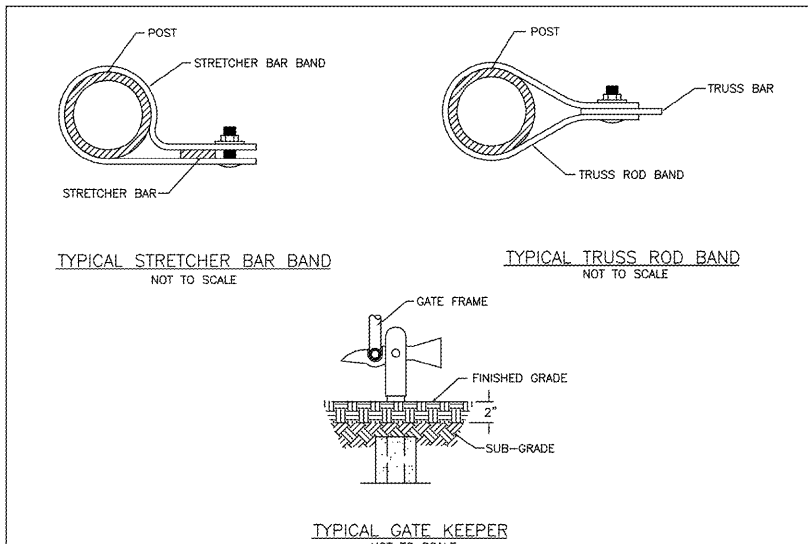

DATE:	12/7/2004	REVISIONS:		STANDARD DETAIL	LEXINGTON COUNTY JOINT MUNICIPAL WATER AND SEWER COMMISSION
SCALE:	NTS			FENCE DETAILS	FILE NO. SP006J

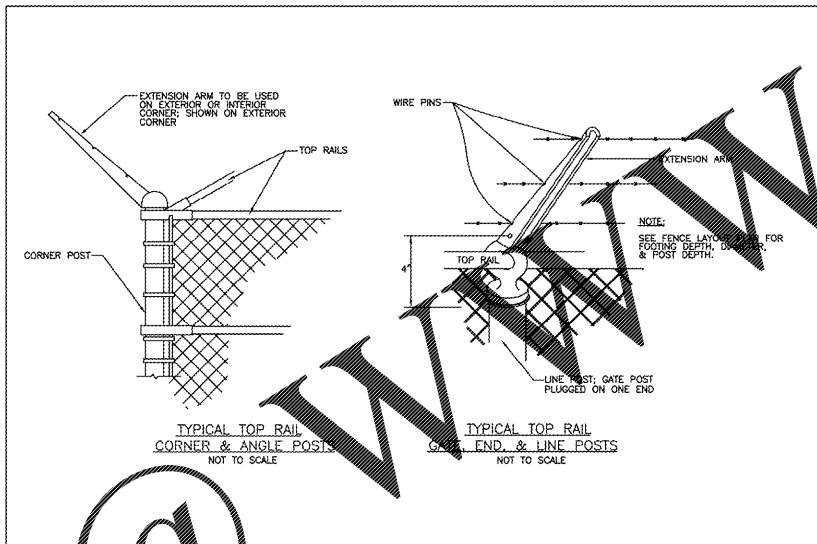

DATE:	12/7/2004	REVISIONS:		STANDARD DETAIL	LEXINGTON COUNTY JOINT MUNICIPAL WATER AND SEWER COMMISSION
SCALE:	NTS			FENCING DETAILS	FILE NO. SP006G

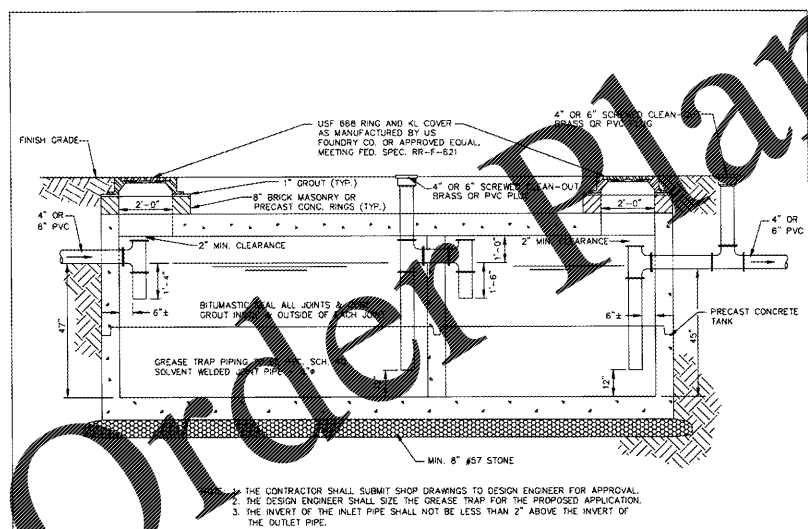

DATE:	JULY, 2010	REVISIONS:	11/10 GENERAL	STANDARD DETAIL	JOINT MUNICIPAL WATER AND SEWER COMMISSION
SCALE:	NTS			PRECAST CONCRETE GREASE TRAP	FILE NO. 71B-9

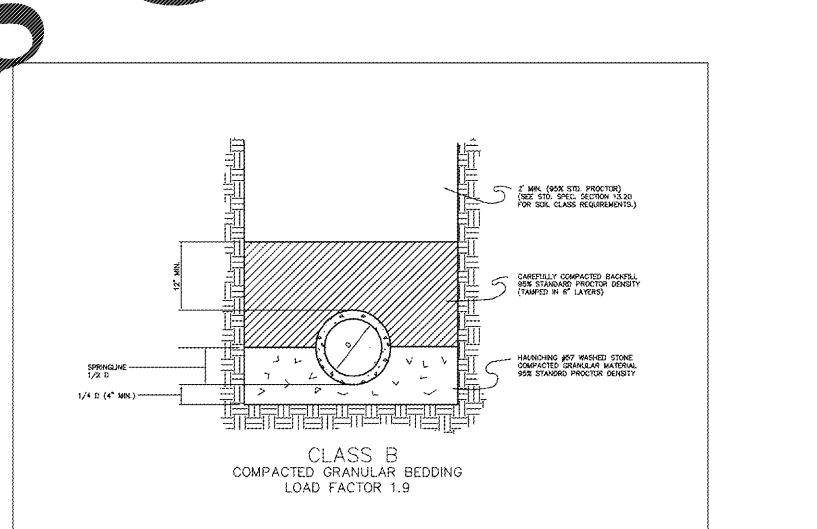

DATE:	7/1/93	REVISIONS:		STANDARD DETAIL	LEXINGTON COUNTY JOINT MUNICIPAL WATER AND SEWER COMMISSION
SCALE:	NTS			STANDARD BEDDING DETAIL FOR PVC SANITARY SEWER PIPE	FILE NO. 71B-5

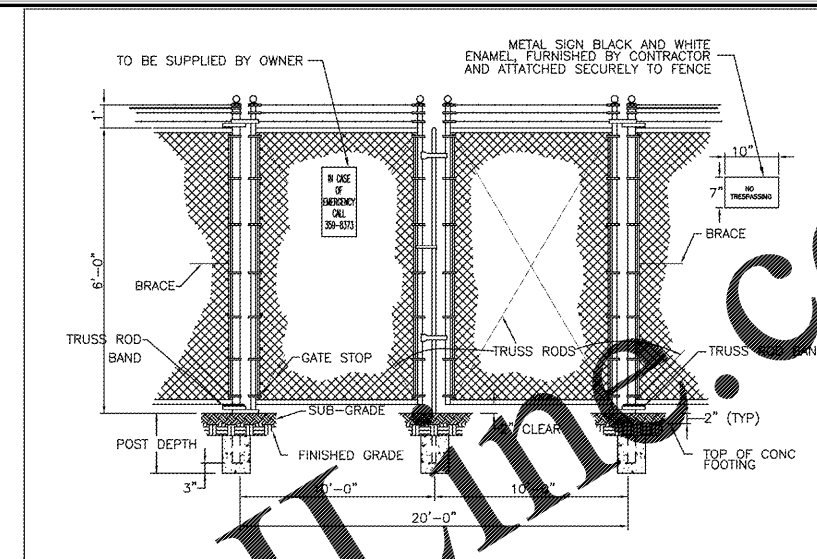

DATE:	12/07/2004	REVISIONS:		STANDARD DETAIL	LEXINGTON COUNTY JOINT MUNICIPAL WATER AND SEWER COMMISSION
SCALE:	NTS			TYPICAL DOUBLE SWING DRIVE GATE	FILE NO. SP006I

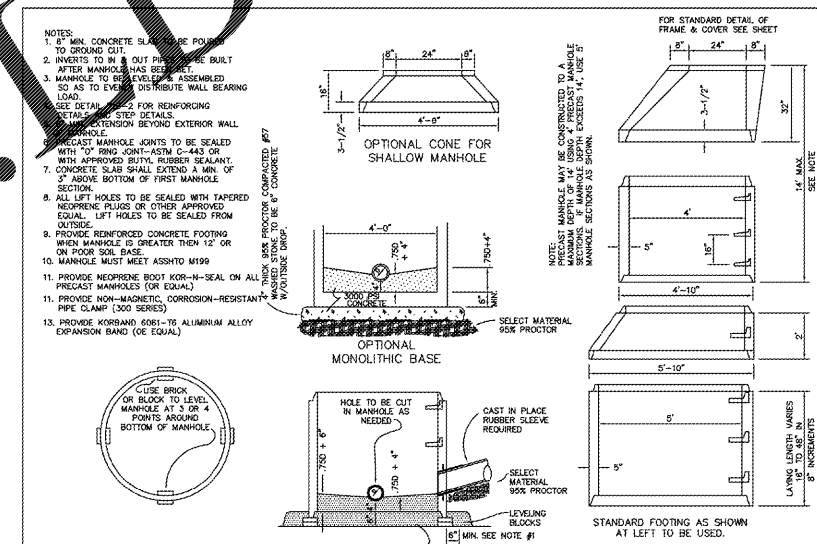

DATE:	7/1/93	REVISIONS:		STANDARD DETAIL	LEXINGTON COUNTY JOINT MUNICIPAL WATER AND SEWER COMMISSION
SCALE:	NTS			PRECAST CONCRETE MANHOLE	FILE NO. 71B-4

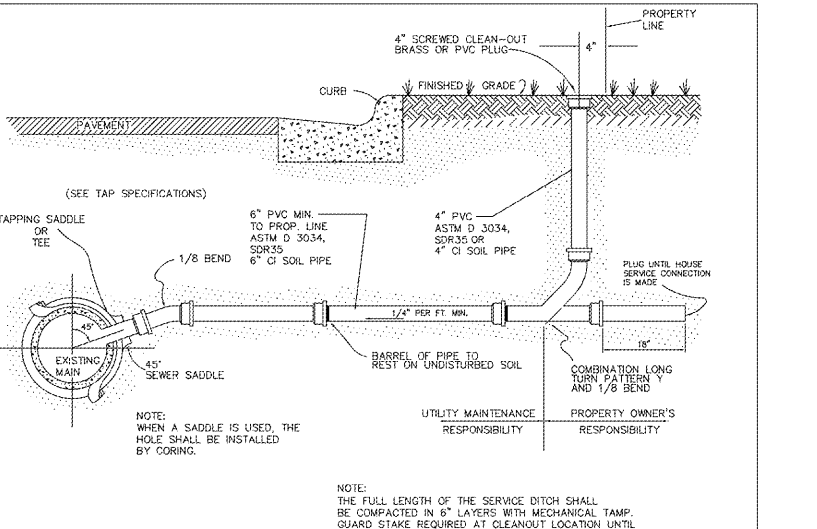

DATE:	7/1/93	REVISIONS:		STANDARD DETAIL	LEXINGTON COUNTY JOINT MUNICIPAL WATER AND SEWER COMMISSION
SCALE:	NTS			SANITARY SEWER LATERAL CONNECTION	FILE NO. 71B-7

COX AND DINKINS
ENGINEERS & SURVEYORS
AND DINKINS, INC.
SOUTH CAROLINA
COLUMBIA, SC 29205
803-254-0518
Fax 803-765-0993
Email: cdinc@coxanddinkins.com

SOUTH CAROLINA
REGISTERED PROFESSIONAL ENGINEER
NO. 14890
COX AND DINKINS, INC.
REGISTERED PROFESSIONAL ENGINEER
NO. 14893

SOUTH CAROLINA
CERTIFICATE OF AUTHORIZATION
COX AND DINKINS, INC.
NO. C00294

NO.	DATE	DESCRIPTION
1	3/22/2017	Revised to add additional sheets
2	4/19/2017	Revised Per Public & Utility company comments
3	7/7/2017	Revised Water and Sanitary Sewer
4	8/6/2017	Revised building footprint
5	9/11/2017	Bid Set

DEVELOPER:
Mr. Tom Murray
WindCrest Development Group
605 East Robinson St. Suite 340
Orlando, Florida 32751
(P) 407.219.3540
(F) 407.219.3541
tmurray@WINDCREST.COM

BID SET
Publix
South Lake Drive & Platt Springs Road
LOCATED NEAR RED BANK
LEXINGTON COUNTY, SOUTH CAROLINA
DETAILS

THIS PROJECT IS IDENTIFIED BY THE FOLLOWING:
TMS 007600-02-005, 006, 013, 084, 095, 116
BOOK N/A SF NO. 245-19A
PROJECT NO. 1920 SHEET NO. C27
DATE 3/15/2017 28 of 48

Order Plans

WINDCREST@WINDCREST.COM

WINDCREST.COM

COPYRIGHT © 2017 COX AND DINKINS, INC. ALL RIGHTS RESERVED. COX AND DINKINS, INC. 11/1/16cm