

WAWA SIGNAGE/STRIPING DETAILS

REV. JULY 28, 2016

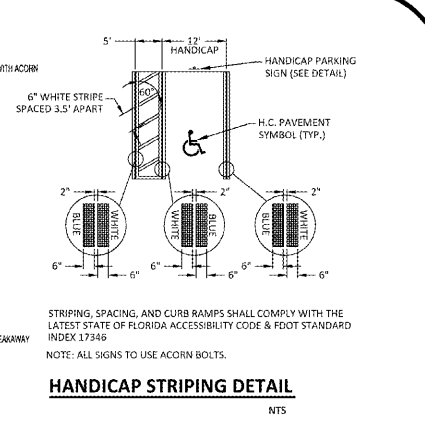
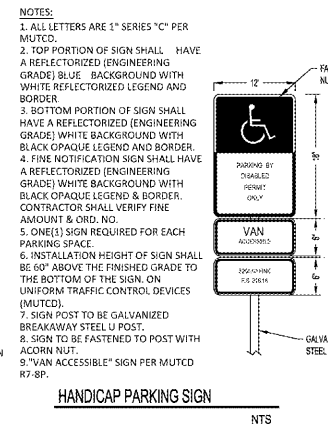
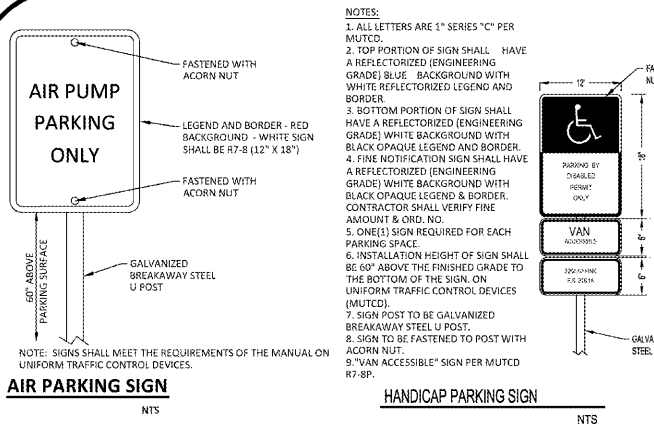

AIR PARKING SIGN
NTS

HANDICAP PARKING SIGN
NTS

HANDICAP STRIPING DETAIL
NTS

SIGNAGE AND STRIPING NOTES:
1. ALL STANDARD PARKING STRIPES ARE TO BE 4" YELLOW
2. ARROWS SHOWN IN DRIVE AISLES ARE FOR INFORMATION ONLY AND SHALL NOT BE PAINTED.

WAWA CURB DETAILS

REV. JULY 28, 2016

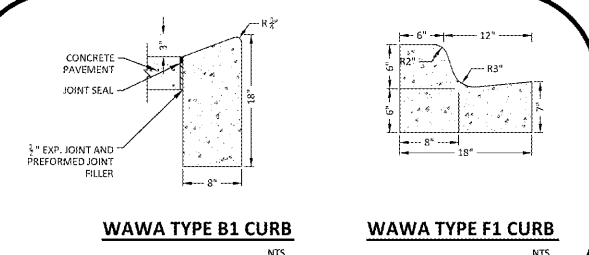

WAWA TYPE B1 CURB NTS
WAWA TYPE F1 CURB NTS

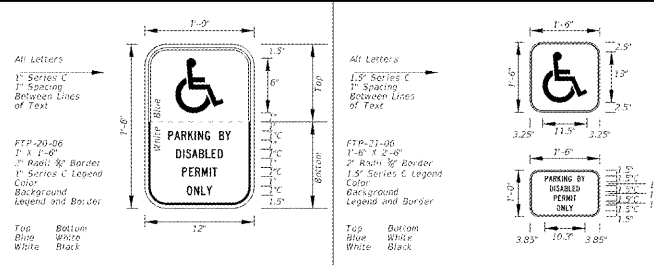

SPECIAL SIGN DETAILS
INDEX NO. 17355 SHEET NO. 2 of 11

EROSION CONTROL DETAILS

REV. JULY 28, 2016

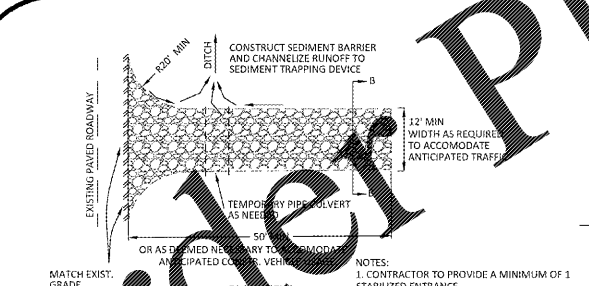

STABILIZED CONSTRUCTION ENTRANCE / EXIT (TYPE 1)
NTS

NOTES:
1. CONTRACTOR TO PROVIDE A MINIMUM OF 1 STABILIZED ENTRANCE.
2. ALL OTHER STATE AND LOCAL JURISDICTION TO BE CONTRACTED AND ADHERED TO.

WAWA GENERAL DETAILS

REV. JULY 28, 2016

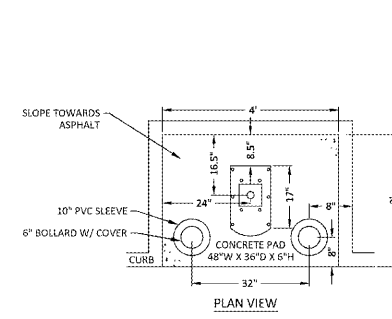
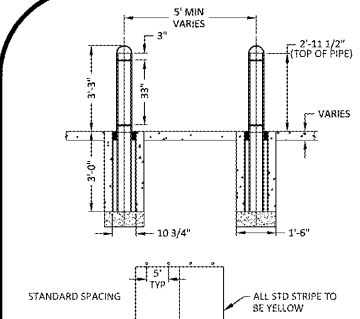

AIR PUMP STAND

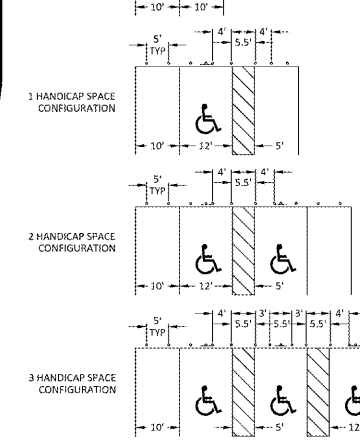

BOLLARD SPACING/DIMENSION DETAIL
NTS

NOTE: ALL DIMENSIONS MEASURED TO CENTER OF BOLLARD. BOLLARD SPACING IS 5' UNLESS OTHERWISE NOTED.

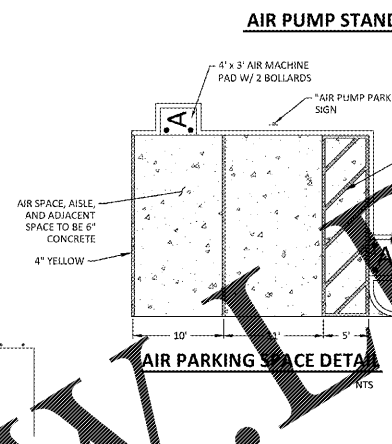

AIR PARKING SPACE DETAIL
NTS

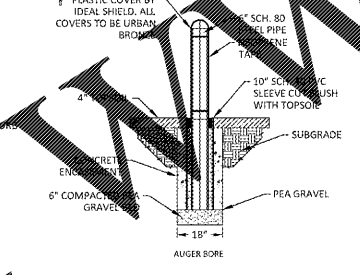

LANDSCAPED AREAS

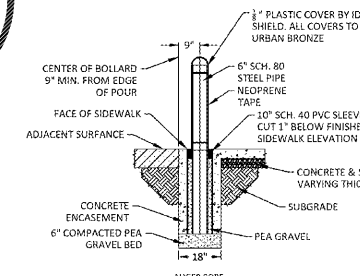

CONCRETE AREAS

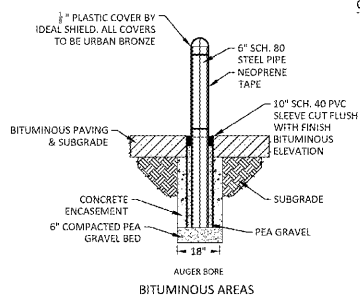

BOLLARD DETAIL
NTS

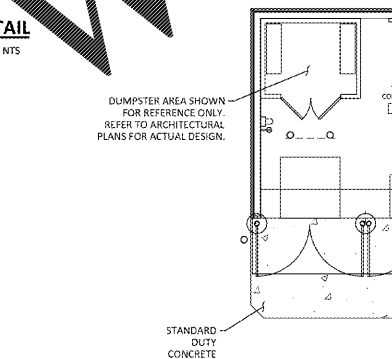

DUMPSTER CONCRETE APRON
NTS

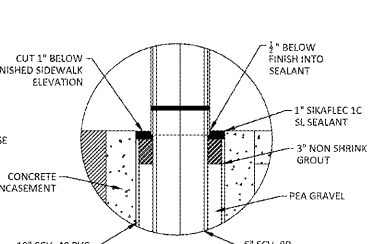

GENERAL DETAILS AND CAULK/GROUT DETAIL FOR CONCRETE AREAS

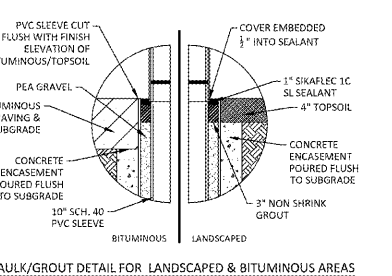

CAULK/GROUT DETAIL FOR LANDSCAPED & BITUMINOUS AREAS

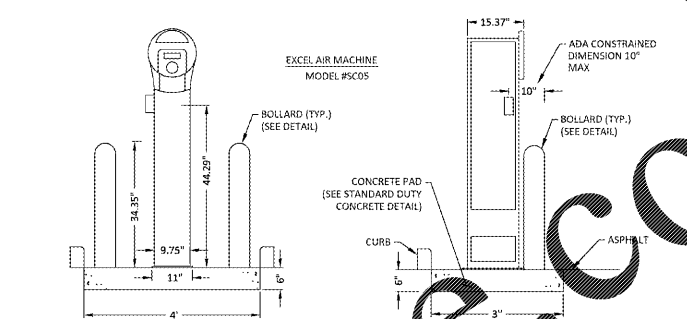

EMERGENCY PUMP SHUTOFF DETAIL
NTS

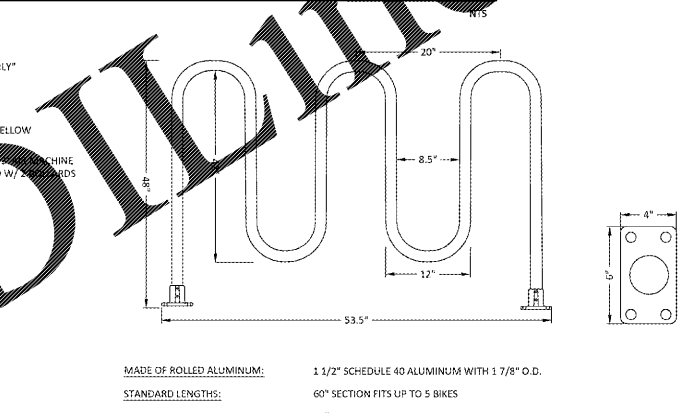

STANDARD BICYCLE RACK DETAIL
NTS

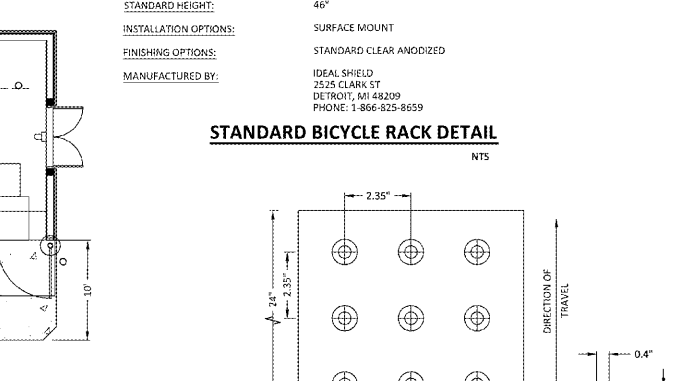

ADA DETECTABLE CURB WARNING DETAIL
ADA DOME TOOL DESIGN - STAMPCRETE INTERNATIONAL NTS

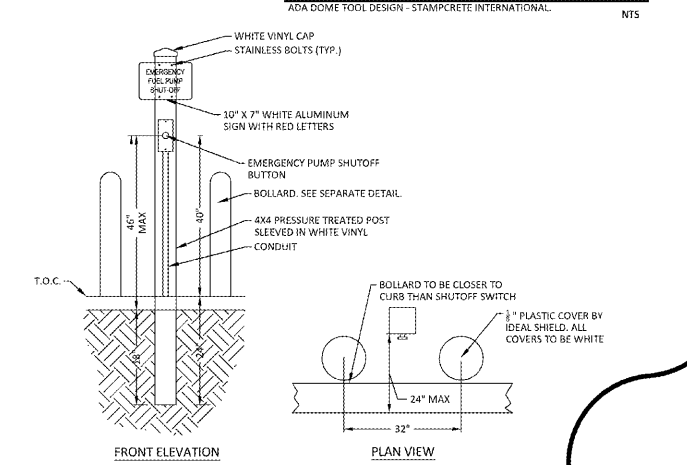

EMERGENCY PUMP SHUTOFF DETAIL
NTS

BOHLER ENGINEERING
SITING, CIVIL AND CONSULTING ENGINEERING
LAND SURVEYING, DESIGN, CONSTRUCTION ADMINISTRATION SERVICES
SUBSTANTIAL DESIGN, PERMITTING SERVICES
• RALEIGH, NC
• CHARLOTTE, NC
• GEORGIA
• TAMPA, FL
• SOUTH FLORIDA
• FORT WORTH, TX
• HOUSTON, TX
• NEW YORK, NY
• BALTIMORE, MD
• SOUTH BEND, IN
• PHOENIX, AZ
• WASHINGTON, DC
• PITTSBURGH, PA

REV	DATE	COMMENT	BY
1	8/9/2016	PER CITY COMMENTS	SMT
2	10/20/2016	REVISIONS PER SFWM COMMENTS	SMT
3	4/10/2017	PER FOOT AND SFWM COMMENTS	DJE
4	4/24/2017	PER CITY OF FORT PIERCE COMMENTS	SGM
5	5/12/2017	PER FDOT COMMENTS	SGM
6	6/21/2017	PER FDOT COMMENTS	SGM
7	7/14/2017	PER FDOT COMMENTS	SGM

811 KNOW WHAT'S BELOW ALWAYS CALL 811 BEFORE YOU DIG
It's fast. It's free. It's the law.
www.callsunshine.com

APPROVED FOR CONSTRUCTION

PROJECT NO.	FLB16009
DRAWN BY:	DJE
CHECKED BY:	CR
DATE:	06/24/16
SCALE:	
CAD I.D.	SD3

PROJECT: **SR 70 AND JENKINS FOR WAWA**
LOCATION OF SITE: SEC SR 70 & S JENKINS RD FORT PIERCE, FLORIDA

BOHLER ENGINEERING
2255 GLADES ROAD, SUITE 305E
BOCA RATON, FLORIDA 33431
Phone: (561) 571-0280
Fax: (561) 571-0281
FLORIDA LICENSE # 39171 OF AUTHORITY # 16100
1000 S.W. 10TH AVENUE, SUITE 1000, BOCA RATON, FL 33432

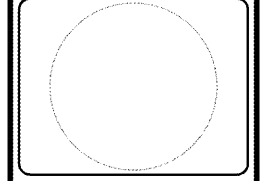

SHEET TITLE: **CONSTRUCTION DETAILS**

SHEET NUMBER: **D-3**

Order Plans