

Interior Finish Schedule

Rm. #	Space Room Name	Floor Finish	Base Finish	North Wall Finish	East Wall Finish	South Wall Finish	West Wall Finish	Ceiling		Remarks
								Finish	Height	
100	--	--								
101	VESTIBULE 1	CARPET TILE - 1	6" STONE	GWB/CULT. STONE on CMU	GWB/CULT. STONE on CMU	GWB/CULT. STONE on CMU	GWB/CULT. STONE on CMU	EXPOSED STRUCT.	VARIES	CEILING HT. 12' TO 16' 48" CULT. STONE WAINSCOT
102	CLASSROOM 1	VCT	6" RB	Painted CMU	Painted CMU	Painted CMU	Painted CMU	ACT - 1	10'-6"	SLIP RESISTANT V.C.T. at A.D.A. RAMP
103	VESTIBULE 2	CARPET TILE - 1	6" STONE	GWB/CULT. STONE on CMU	GWB/CULT. STONE on CMU	GWB/CULT. STONE on CMU	GWB/CULT. STONE on CMU	EXPOSED STRUCT.	VARIES	CEILING HT. 12' TO 16' 48" CULT. STONE WAINSCOT
104	MEETING ROOM 1	CARPET TILE - 2	6" RB	GWB on CMU	GWB on CMU	GWB on CMU	GWB on CMU	ACT - 1 & GWB	VARIES	CEILING HT. 15' & 17' 48" WOOD PANEL WAINSCOT
105	MEETING ROOM 2	CARPET TILE - 2	6" RB	GWB on CMU	GWB on CMU	GWB on CMU	GWB on CMU	ACT - 1 & GWB	VARIES	CEILING HT. 15' & 17' 48" WOOD PANEL WAINSCOT
106	HALL 1	VCT	6" RB	Painted CMU	Painted CMU	Painted CMU	Painted CMU	ACT - 1	12'-0"	
107	CLASSROOM 2	VCT	6" RB	Painted CMU	Painted CMU	Painted CMU	Painted CMU	ACT - 1	12'-0"	
108	CLASSROOM 3	VCT	6" RB	Painted CMU	Painted CMU	Painted CMU	Painted CMU	ACT - 1	12'-0"	
109	VESTIBULE 3	CARPET TILE - 1	6" RB	Painted CMU	Painted CMU	Painted CMU	Painted CMU	ACT - 1	12'-0"	
110	FAMILY RESTROOM 1	CERAMIC	C.T.	CERAMIC TILE	CERAMIC TILE	CERAMIC TILE	CERAMIC TILE	ACT - 2	8'-0"	DECORATIVE CERAMIC BAND ACCENT
111	MEN 1	CERAMIC	C.T.	CERAMIC TILE	CERAMIC TILE	CERAMIC TILE	CERAMIC TILE	ACT - 2	10'-0"	DECORATIVE CERAMIC BAND ACCENT
112	WOMEN 1	CERAMIC	C.T.	CERAMIC TILE	CERAMIC TILE	CERAMIC TILE	CERAMIC TILE	ACT - 2	10'-0"	DECORATIVE CERAMIC BAND ACCENT
113	JANITOR	CERAMIC	C.T.	Painted CMU	Painted CMU	Painted CMU	Painted CMU	ACT - 2	10'-0"	
114	MECHANICAL	SEALED CONC.	NONE	Painted CMU	Painted CMU	Painted CMU	Painted CMU	EXP. STRUCT.	VARIES	
115	ELECTRICAL	SEALED CONC.	NONE	Painted CMU	Painted CMU	Painted CMU	Painted CMU	EXP. STRUCT.	VARIES	
116	KITCHEN	Q.T.	Q.T.	F.R.P. PANELS	F.R.P. PANELS	F.R.P. PANELS	F.R.P. PANELS	ACT - 2	10'-0"	
117	STAFF RESTROOM	Q.T.	Q.T.	F.R.P. PANELS	F.R.P. PANELS	F.R.P. PANELS	F.R.P. PANELS	ACT - 2	10'-0"	
118	WOMEN 2	CERAMIC	C.T.	CERAMIC TILE	CERAMIC TILE	CERAMIC TILE	CERAMIC TILE	ACT - 2	10'-0"	DECORATIVE CERAMIC BAND ACCENT
119	MEN 2	CERAMIC	C.T.	CERAMIC TILE	CERAMIC TILE	CERAMIC TILE	CERAMIC TILE	ACT - 2	10'-0"	DECORATIVE CERAMIC BAND ACCENT
120	FAMILY RESTROOM 2	CERAMIC	C.T.	CERAMIC TILE	CERAMIC TILE	CERAMIC TILE	CERAMIC TILE	ACT - 2	8'-0"	DECORATIVE CERAMIC BAND ACCENT
121	VESTIBULE 4	CARPET TILE - 1	6" RB	Painted CMU	Painted CMU	Painted CMU	Painted CMU	ACT - 1	12'-0"	
122	HALL 2	VCT	6" RB	Painted CMU	Painted CMU	Painted CMU	Painted CMU	ACT - 1	12'-0"	
123	CLASSROOM 4	VCT	6" RB	Painted CMU	Painted CMU	Painted CMU	Painted CMU	ACT - 1	12'-0"	
124	CLASSROOM 5	VCT	6" RB	Painted CMU	Painted CMU	Painted CMU	Painted CMU	ACT - 1	12'-0"	
125	HALL 3	VCT	6" RB	Painted CMU	Painted CMU	Painted CMU	Painted CMU	ACT - 1	12'-0"	
126	STORAGE 1	VCT	6" RB	Painted CMU	Painted CMU	Painted CMU	Painted CMU	ACT - 1	12'-0"	
127	STORAGE 2	VCT	6" RB	Painted CMU	Painted CMU	Painted CMU	Painted CMU	ACT - 1	12'-0"	
128	STORAGE	Q.T.	Q.T.	F.R.P. PANELS	F.R.P. PANELS	F.R.P. PANELS	F.R.P. PANELS	ACT - 2	12'-0"	

Fiber Reinforced Panels (FRP) (Discuss installation procedures with Owner prior to installing)

LP-F9 .090" Textured Fiber-Lite Liner panels (no substrate) as manufactured by Nudo Products, Inc., 1500 Taylor Ave, Springfield, IL 62703-5640, (800) 826-4132 or equal, installed over 1/2" plywood or prelaminated by the manufacturer. Assume all surfaces are clean, flat, dry and smooth, correct uneven surfaces prior to installation. Use manufacturer's 4' x 8', 10', 12' as best suited for the minimum number of joints per installation. Color, number 148, white.

Store panels in a dry area. Do not store outdoors. Panels should be unwrapped and removed from skid and stacked on a flat, dry surface. Panels should be pre-conditioned for at least 24 hours in temperature and humidity conditions of installation area(s). Take normal fire-safety precautions when storing and using panels.

Fiber-Lite Liner panels will expand and contract. Allow a 1/8" gap at ceiling and base and 1/16" between panel and division bar for panel expansion and contraction. Follow manufacturers recommendations for expansion and contraction in high humidity areas.

Pre-drilled holes for Fiber-Lite Liner Panel should be slightly less than diameter of fastener shank to allow for normal expansion and contraction. Allow for expansion of panels when installing around pipes, conduits, electrical outlets, etc.. Use of moldings and silicone sealant with panels is required to achieve a moisture resistant installation.

Provide all necessary moldings and trims for a complete installation as recommended by manufacturer. Cut moldings to size and place Super Silicone Sealant (SSW or SSW-2) or equivalent into channel of molding during installation. Place molding on panel before fastening, if required. Place silicone between molding and floor to prevent moisture from penetrating back of panel substrate. Sealants shall be installed to seal and bond vinyl moldings to panel edge. Seal division joints between wall and ceiling panels, seal around installation. Use manufacturer's recommended adhesive and sealant products. fasteners and installation. Use manufacturer's recommended adhesive and sealant products.

Manufacturer's trims and fasteners are required as follows and as necessary for a complete installation.

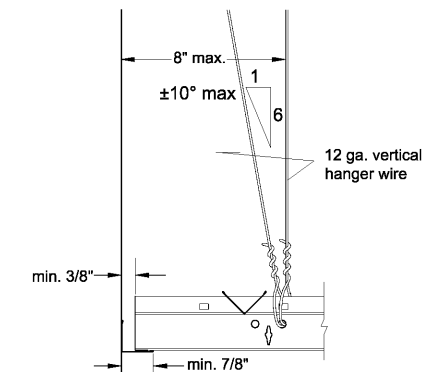

Edge Mold and Stabilizers

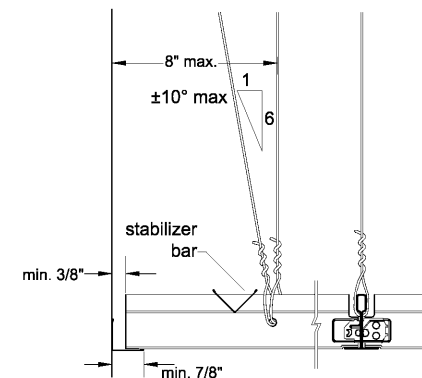

Comments, Additional information:

1. XX
 2. XX
 3. XX
- See Sheet --- for Door Window Elevations

General Notes:

1. All exterior walls furred with min R-8 rigid insulation. See details for 5/8" GWB interior surface locations.
2. All exposed CMU, steel and miscellaneous metals, etc. are painted, see Section 09900.
3. Meeting Rooms shall have sound partitions from top of CMU to underside of roof deck, tight.
4. Partitions not extending to structure shall be at least 8" above ceiling heights. All jamb returns shall be a minimum of 4".
5. All gypsum board walls and ceilings are painted. See Section 09900.

Order Plans @ WWW.LDMLINE.COM

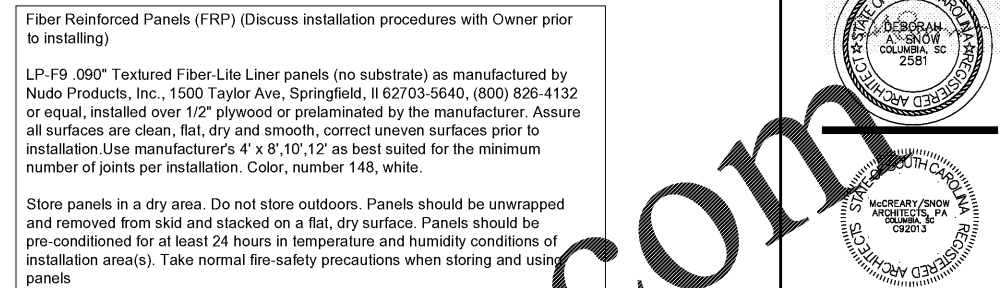

McCreary/Snow Architects, PA
Architects and Planners
2210 Dewey Street (29205)
Columbia, South Carolina 29211
803.777.6267
cm@msarch.com

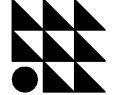

Finish Schedule
Pinewood Community Bldg.
Richland County
Old Garners Ferry Road
Columbia, SC 29209

File date: 8/22/2017

Construction Documents

Checked:-

Drawn: -

Revised: -

Project No.: #####

File: -

a4.1

Sheet Number
AUGUST 22, 2017
Date