

1 - Truss Girder/ Jack Truss to CMU

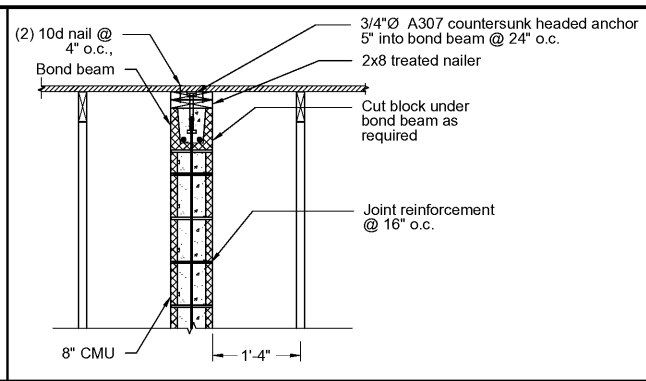

2 - Typical Roof Section Between Units

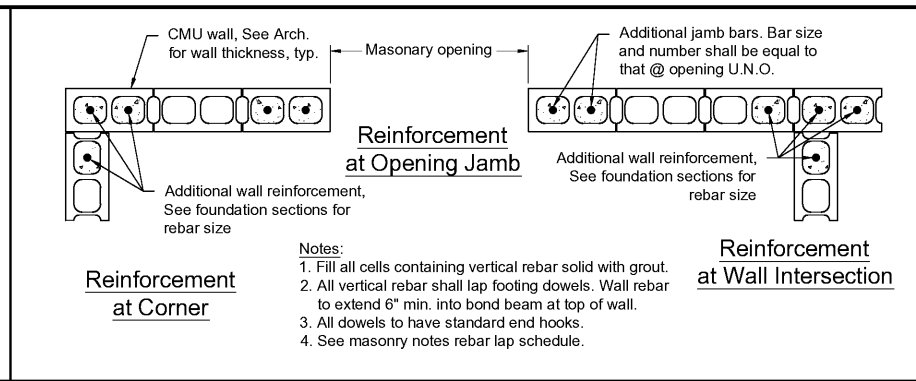

3 - Typical Masonry Wall Reinforcement Details

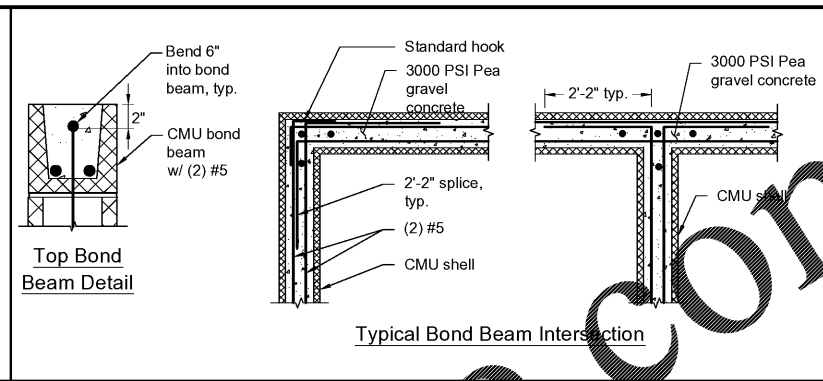

4 - Typical Details

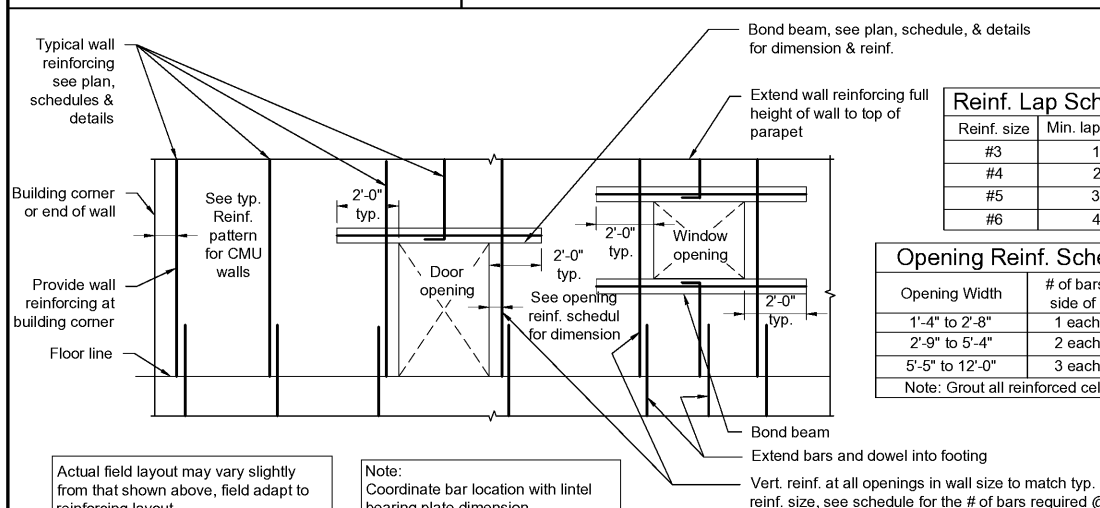

5 - Typical Reinforcing @ Penetrations Through CMU Walls or Similar Condition

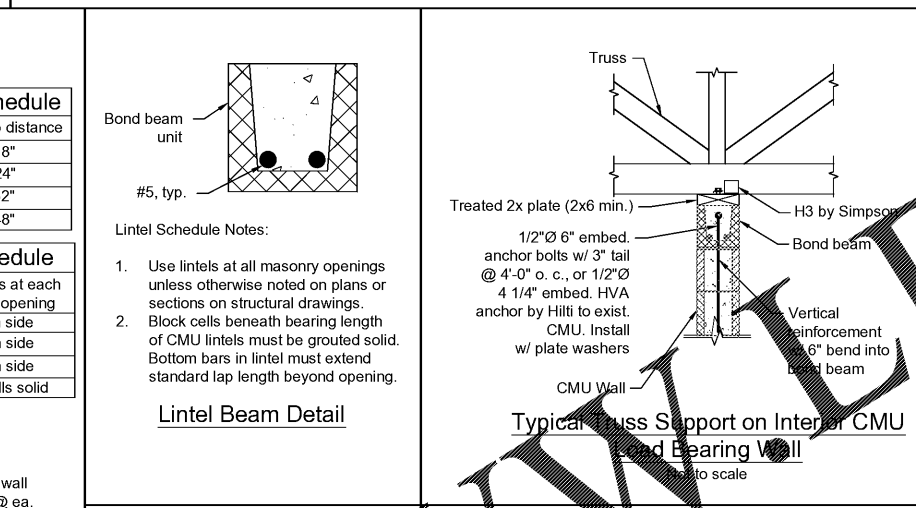

6 - Typical Detail 7 - Typical Detail 8 - Typical Detail

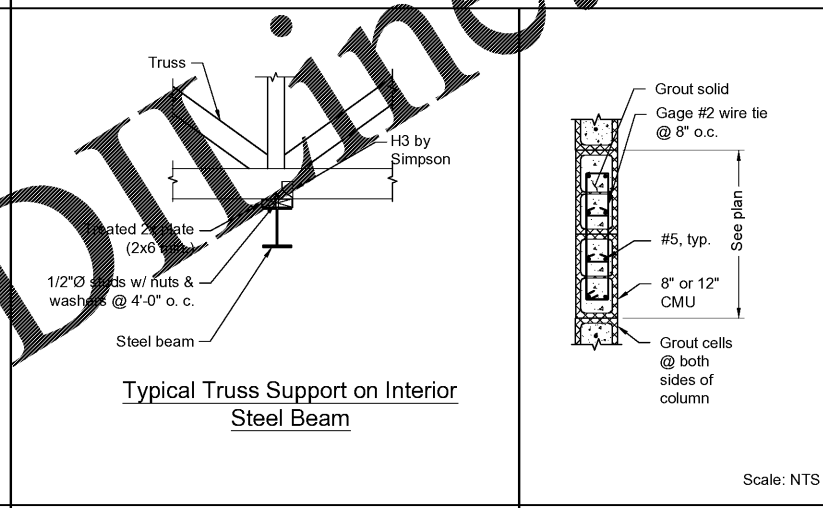

9 - Masonry Column

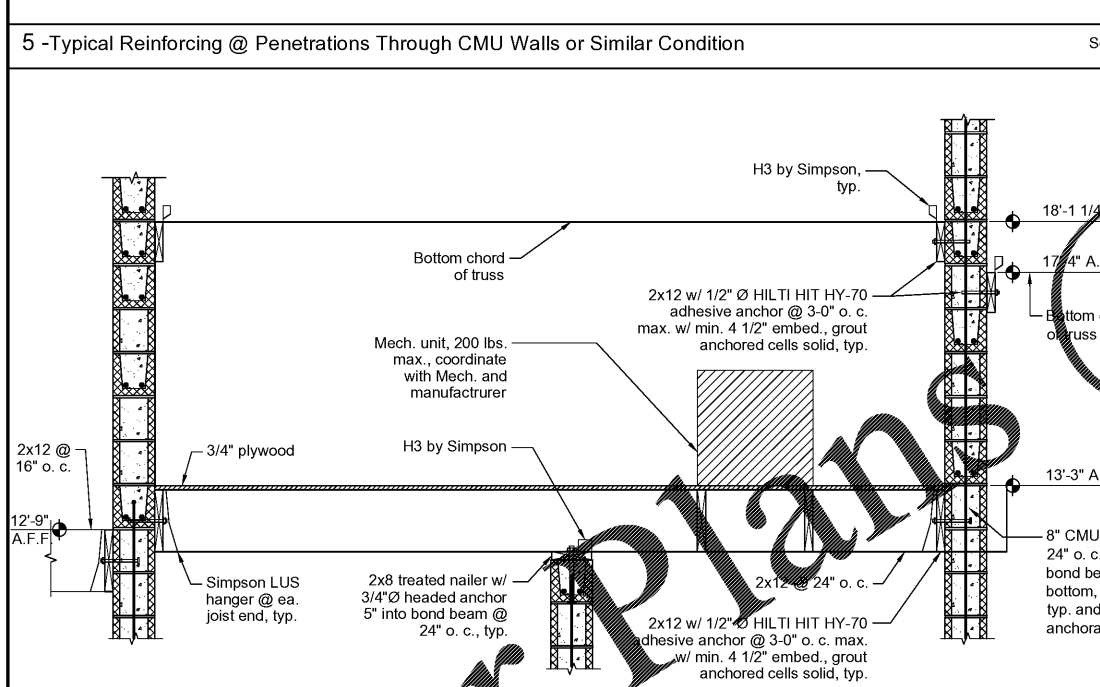

10 - Section

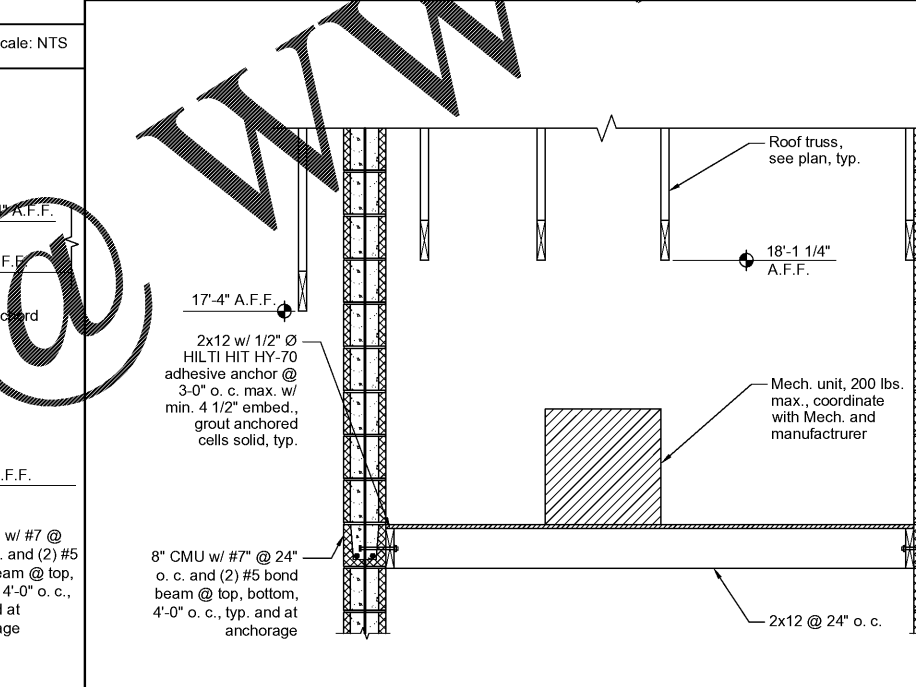

11 - Section

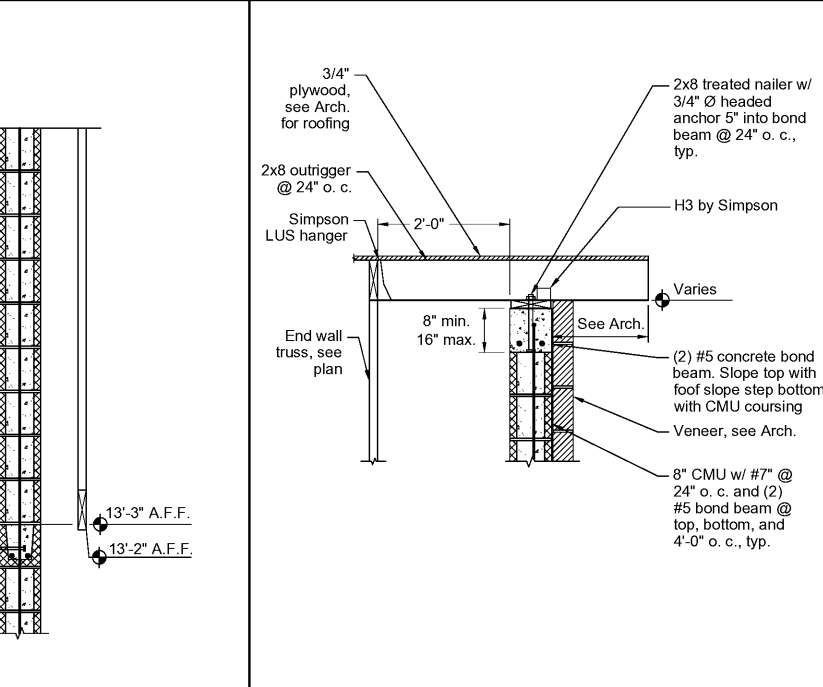

12 - Section

Order Plans @

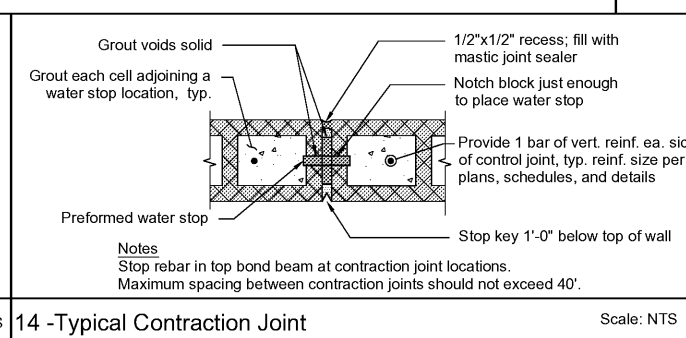

14 - Typical Contraction Joint

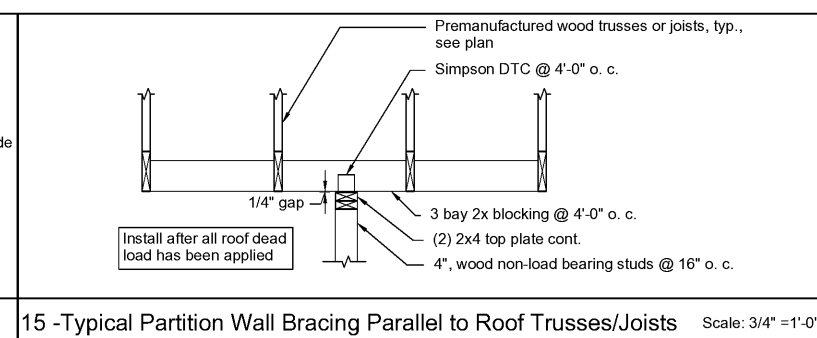

15 - Typical Partition Wall Bracing Parallel to Roof Trusses/Joists

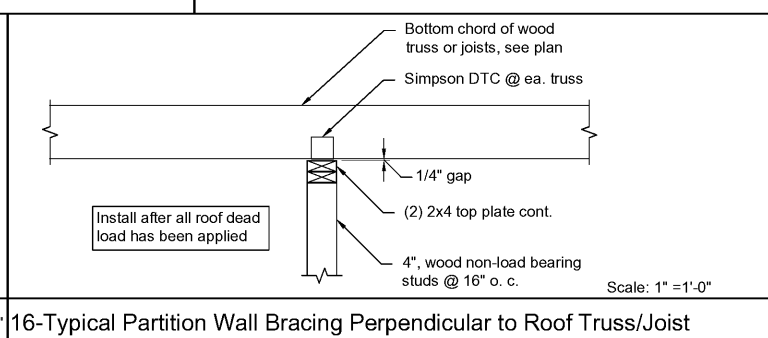

16 - Typical Partition Wall Bracing Perpendicular to Roof Truss/Joist

CHAO & ASSOCIATES, INC.
 CONSULTING ENGINEERS & LAND SURVEYORS
 Civil - Structural - Survey
 7 Clusters Court
 Columbia, SC 29210
 Voice: (803) 772-8420
 Fax: (803) 772-9120
 Email: consult@chaoinc.com



Framing Sections and Details
 Pinewood Community Building
 Richland County
 Old Garners Ferry Road
 Columbia, SC 29209

Checked: _____
 Drawn: _____
 Revised: _____
 File: 399935D-17S-BLDG.dwg Project No.: 399935D

S2.2
 Sheet Number
 8/25/2017
 Date