

1 SECTION
3/4" x 1'-0"

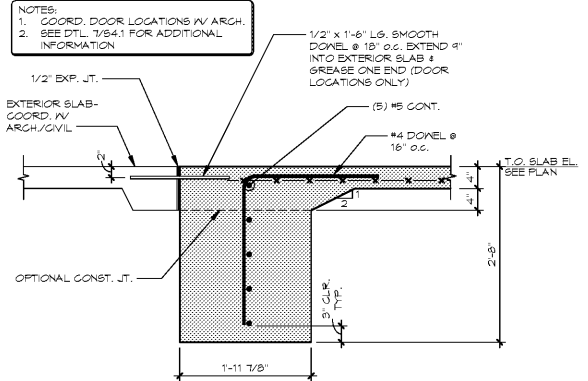

2 SECTION
3/4" x 1'-0"

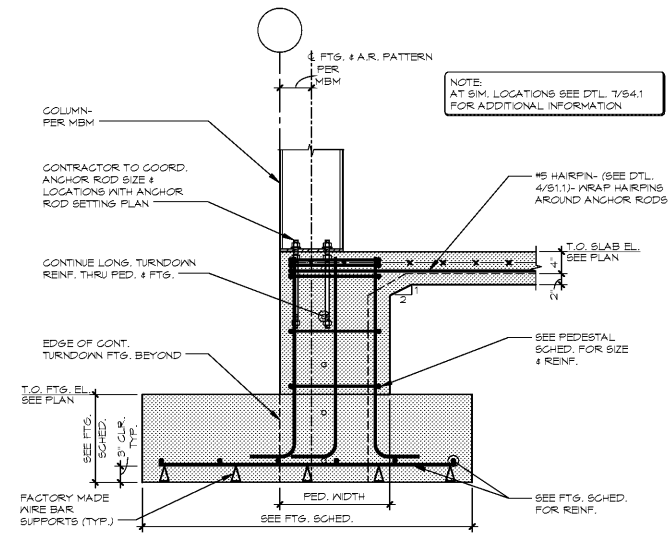

3 SECTION
3/4" x 1'-0"

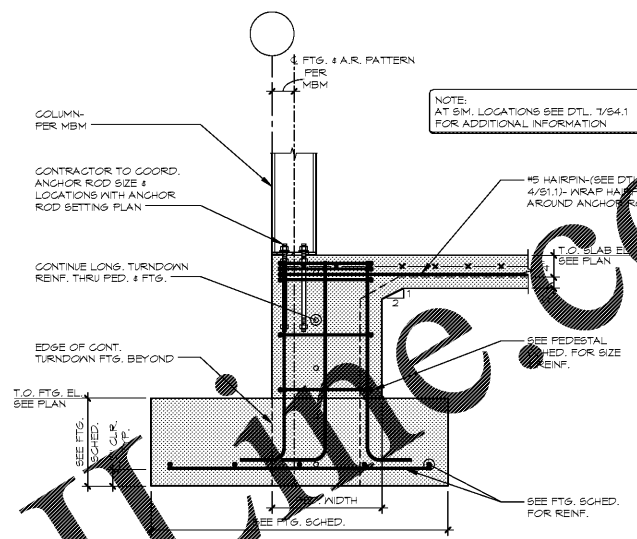

4 SECTION
3/4" x 1'-0"

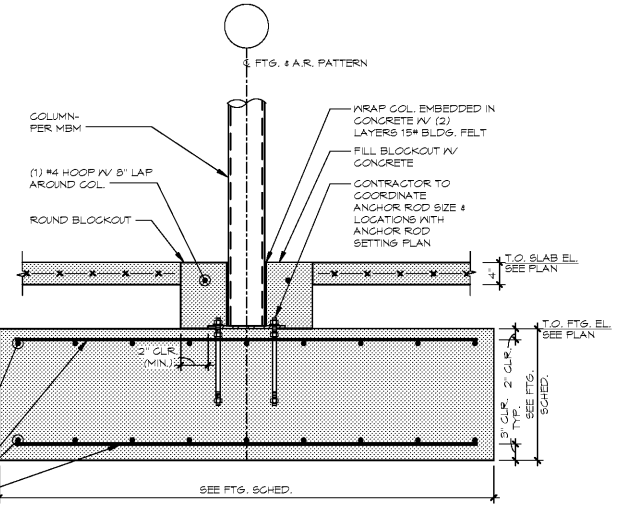

5 SECTION
3/4" x 1'-0"

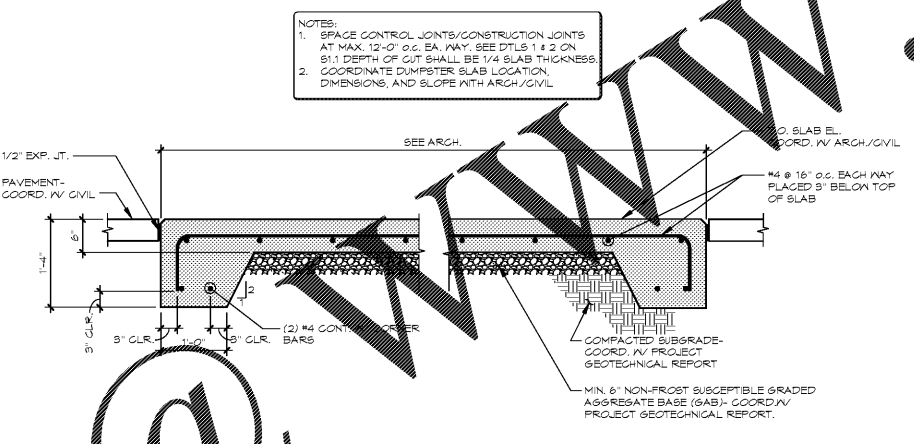

6 TYP. DUMPSTER SLAB DETAIL
3/4" x 1'-0"

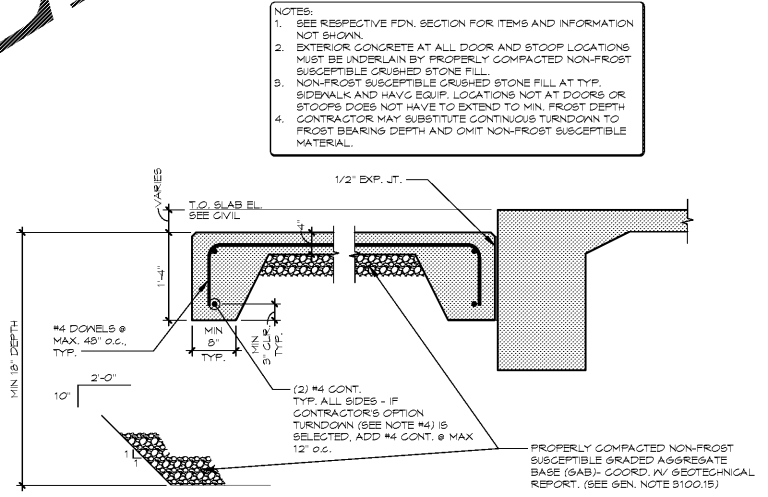

7 TYP. SIDEWALK & HVAC SLAB AT CONT. FTG SECTION
3/4" x 1'-0"

NOTES:
 1. SPACE CONTROL JOINTS/CONSTRUCTION JOINTS AT MAX. 12'-0" o.c. EA. WAY. SEE DTLS 1 & 2 ON S1.1 DEPTH OF CUT SHALL BE 1/4 SLAB THICKNESS.
 2. COORDINATE DUMPSTER SLAB LOCATION, DIMENSIONS, AND SLOPE WITH ARCH./CIVIL

NOTES:
 1. SEE RESPECTIVE FDN. SECTION FOR ITEMS AND INFORMATION NOT SHOWN.
 2. EXTERIOR CONCRETE AT ALL DOOR AND STOOFF LOCATIONS MUST BE UNDERLAIN BY PROPERLY COMPACTED NON-FROST SUSCEPTIBLE CRUSHED STONE FILL.
 3. NON-FROST SUSCEPTIBLE CRUSHED STONE FILL AT TYP. SIDEWALK AND HVAC EQUIP. LOCATIONS NOT AT DOORS OR STOOFFS DOES NOT HAVE TO EXTEND TO MIN. FROST DEPTH. CONTRACTOR MAY SUBSTITUTE CONTINUOUS TURNDOWN TO FROST BEARING DEPTH AND OMIT NON-FROST SUSCEPTIBLE MATERIAL.

STIPULATION FOR REUSE
 THIS DRAWING AND THESE SPECIFICATIONS ARE THE PROPERTY OF TATUM SMITH ENGINEERS, INC. AND ARE NOT TO BE REPRODUCED OR TRANSMITTED IN ANY FORM OR BY ANY MEANS, ELECTRONIC OR MECHANICAL, INCLUDING PHOTOCOPYING, RECORDING, OR BY ANY INFORMATION STORAGE AND RETRIEVAL SYSTEM. WITHOUT THE WRITTEN PERMISSION OF TATUM SMITH ENGINEERS, INC. THE USER OF THIS DRAWING OR THESE SPECIFICATIONS AGREES TO HOLD TATUM SMITH ENGINEERS, INC. HARMLESS FROM ANY AND ALL LIABILITY ARISING FROM SUCH REUSE. THIS AGREEMENT SHALL BE BOUNDING ON THE USER AND HIS SUCCESSORS AND ASSIGNEES. PROJECT REPRODUCTION OF THIS DRAWING OR THESE SPECIFICATIONS WITHOUT THE WRITTEN PERMISSION OF TATUM SMITH ENGINEERS, INC. IS NOT AUTHORIZED AND MAY BE CONSIDERED AS A VIOLATION OF THE LAW.

FAMILY DOLLAR STORE
 1145 WHITE HORSE RD.
 GREENVILLE, SOUTH CAROLINA
 JOB NUMBER: 2017-0123

ISSUE BLOCK		
NO.	ISSUE	DATE

CHECKED BY: RWM
 DRAWN BY: MCW
 PROTO CYCLE: 2016-01
 DOCUMENT DATE: 06/22/17



FOUNDATION DETAILS

SHEET: S4.1

Order Plans