

NOT USED SCALE: 12

TIME CLOCK SCALE: 1" = 1'-0" 9

SHELVING / HANGROD SECTION SCALE: 1" = 1'-0" 9

NOT USED SCALE: N.T.S. 3

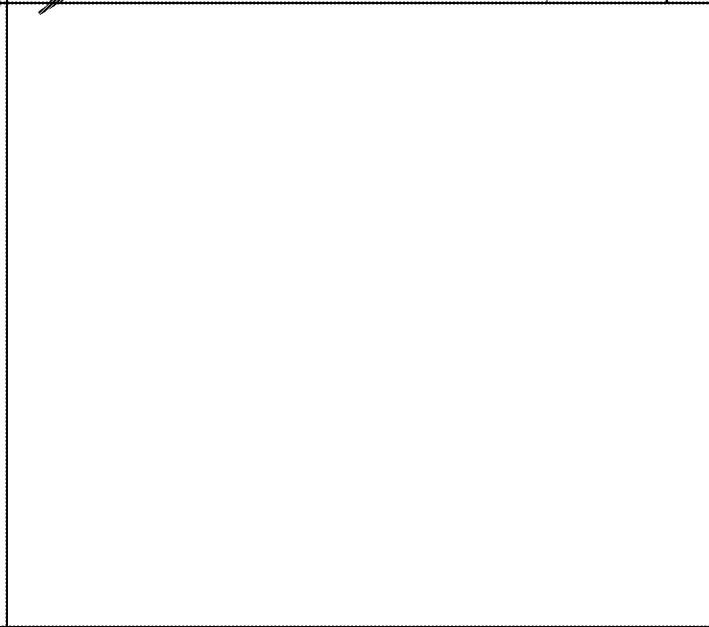
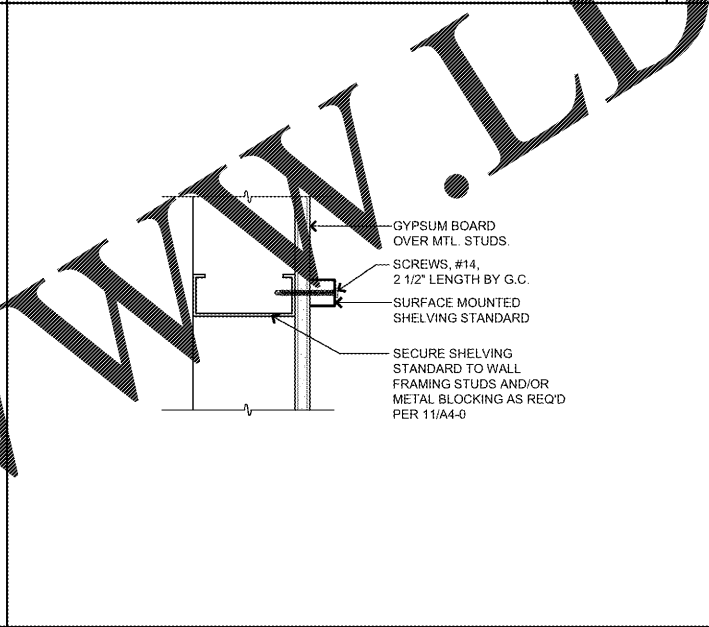
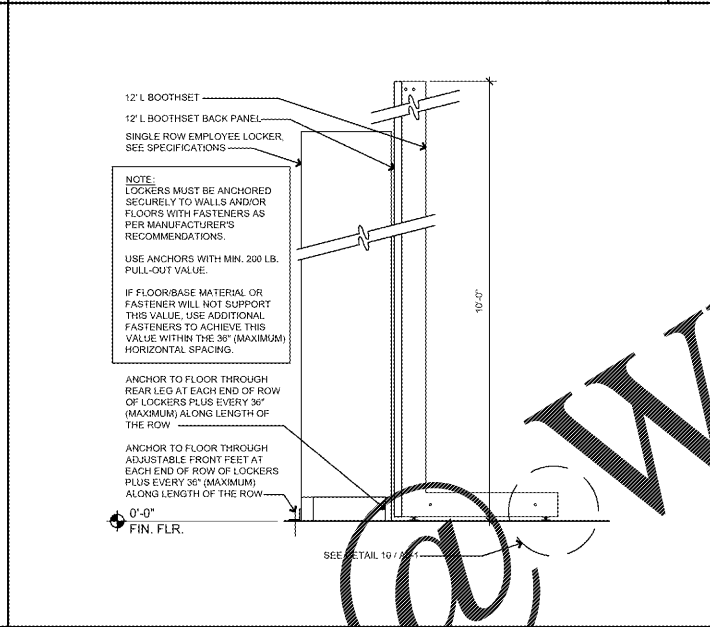
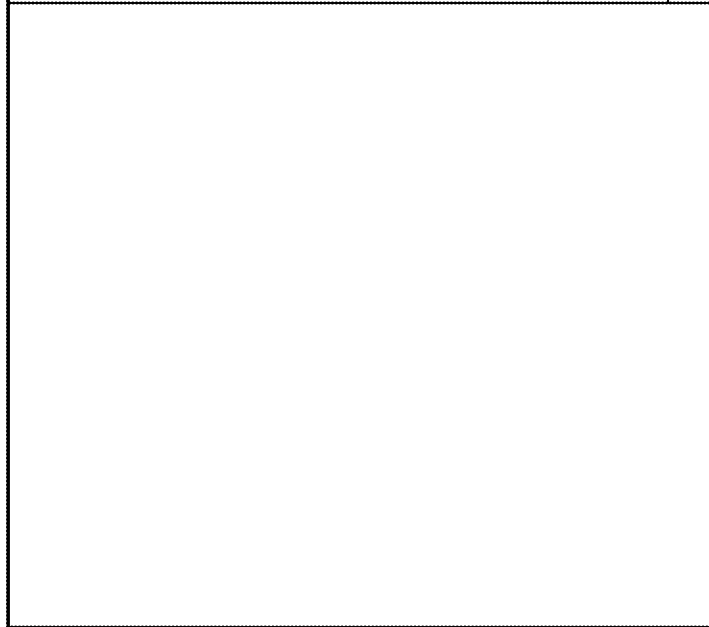

NOT USED SCALE: 11

LOCKER ANCHORING DETAIL SCALE: 3/4" = 1'-0" 8

PLAN DETAIL @ SHELVING STANDARD SCALE: 3" = 1'-0" 5

NOT USED SCALE: 1/8" = 1'-0" 2

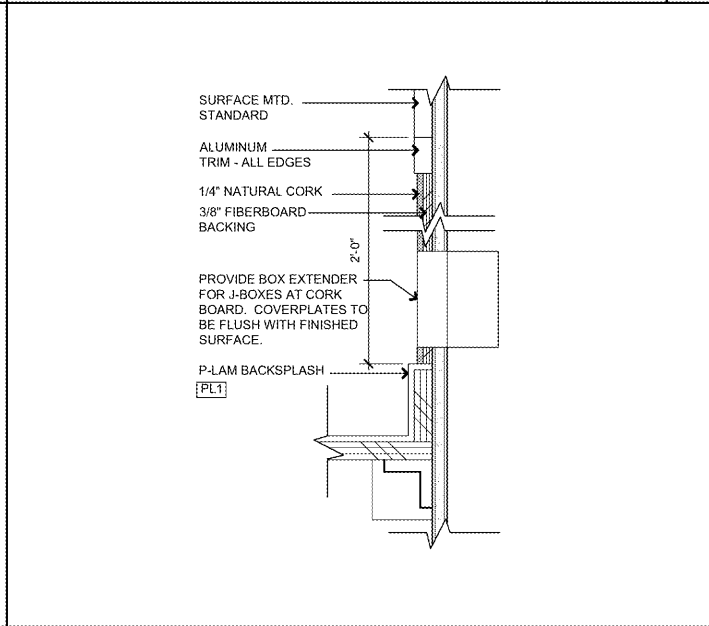
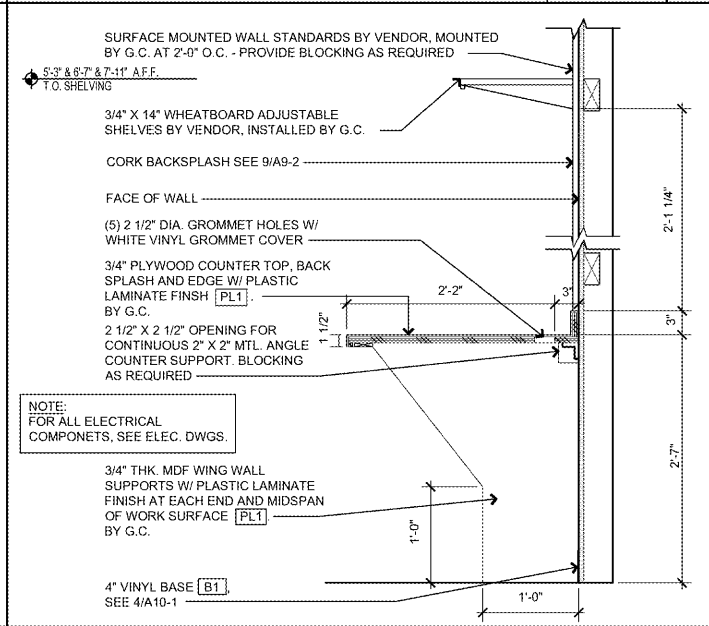
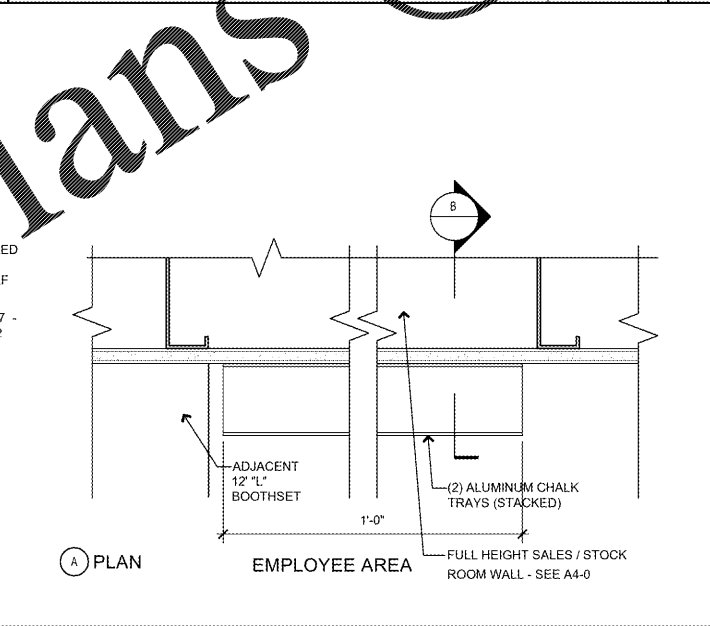
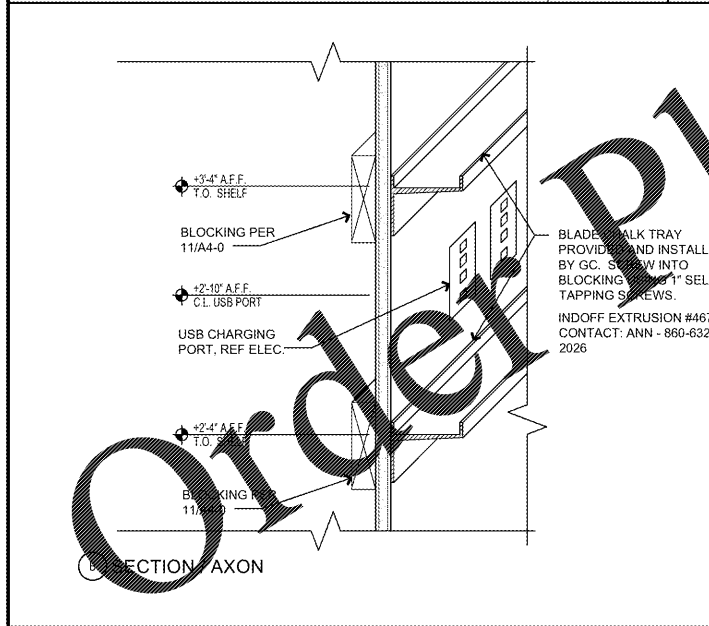

PHONE CHARGING SHELF - PLAN & AXON SCALE: 3" = 1'-0" 7

MANAGER'S OFFICE COUNTERTOP SCALE: 4

SECTION @ CORK BOARD SCALE: 1

SCALE: 3" = 1'-0" 1

NEW STORE  
**OLD NAVY**  
 CAP, INC.  
 CORPORATE ARCHITECTURE  
 HARRIS STREET  
 SAN FRANCISCO, CA 94105  
 REPS. I.D.: 0000054156  
 STORE NUMBER: 4458  
 STORE LOCATION: VINELAND  
 8231 VINELAND AVENUE  
 SUITE 2151  
 ORLANDO, FLORIDA 32821

DESIGN TYPE: P3  
 GENERATION: 17012  
 PROTOTYPE DATE: 07/18/16  
 OPENING: 2017

CONSULTANT INFO:

PROFESSIONAL STAMP:

ARCHITECT INFO:  
**B | R | R**  
 architecture  
 ARCHITECT OF RECORD: BRB ARCHITECTURE, INC.  
 6700 ANTIOCH PLAZA, SUITE 300, HENRIETTA, KANSAS 66044

ISSUE TYPE:  
 PERMIT/BID: 04/07/17

REVISIONS:

DRAWN BY: EE  
 A/E JOB NUMBER: 65013011  
 TITLE SHEET:  
 STOCK / PROCESSING  
 AREA ELEVATIONS &  
 DETAILS  
 SHEET NUMBER:  
**A9-1**