

147 Wappoo Creek Drive  
Suite 400  
Charleston, SC 29412

P 843.762.2222

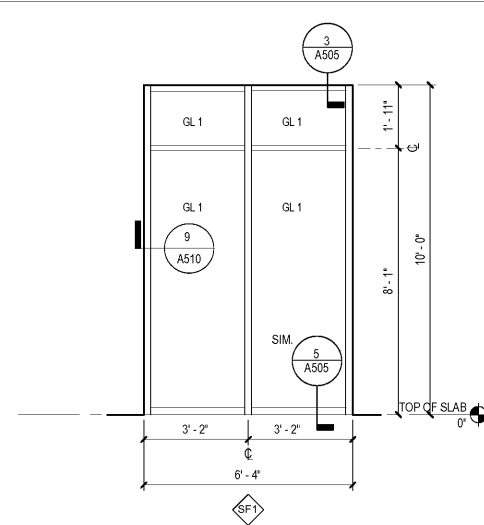

1 SF1  
A602 SCALE: 3/8" = 1'-0"

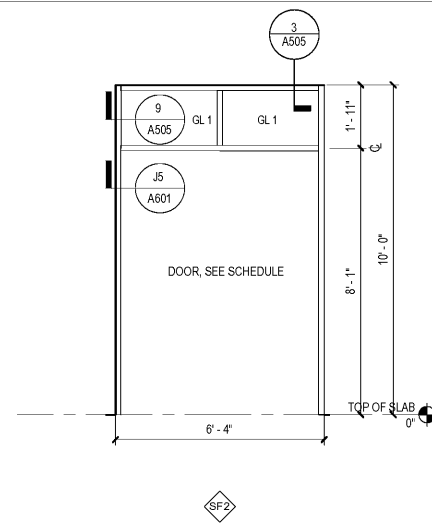

2 SF2  
A602 SCALE: 3/8" = 1'-0"

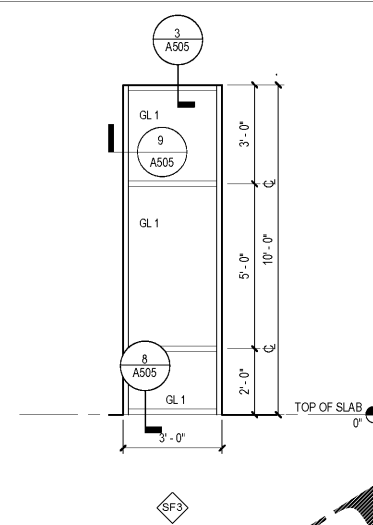

3 SF3  
A602 SCALE: 3/8" = 1'-0"

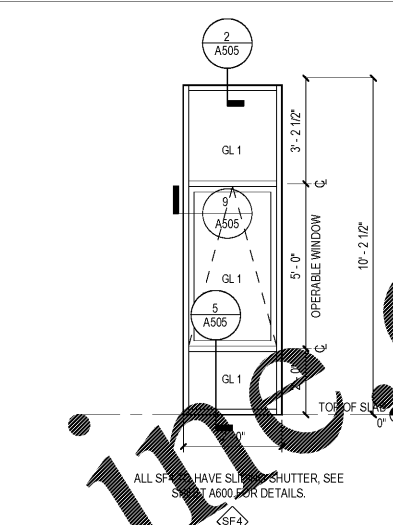

4 SF4  
A602 SCALE: 3/8" = 1'-0"

ALL SF'S HAVE SLIDING SHUTTER, SEE SHEET A600 FOR DETAILS.

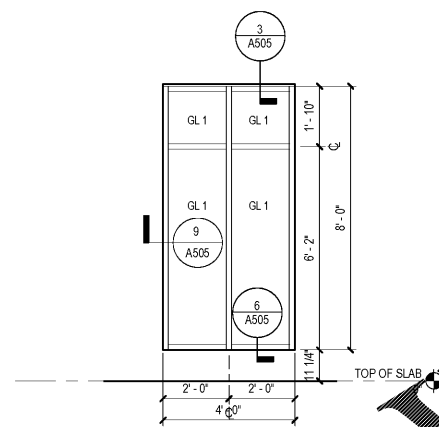

5 SF5  
A602 SCALE: 3/8" = 1'-0"

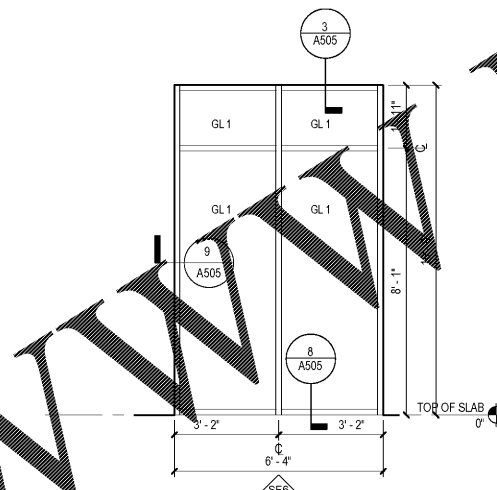

6 SF6  
A602 SCALE: 3/8" = 1'-0"

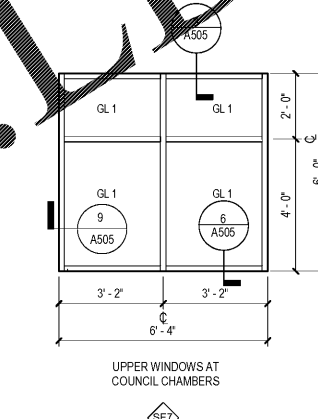

7 SF7  
A602 SCALE: 3/8" = 1'-0"

UPPER WINDOWS AT COUNCIL CHAMBERS

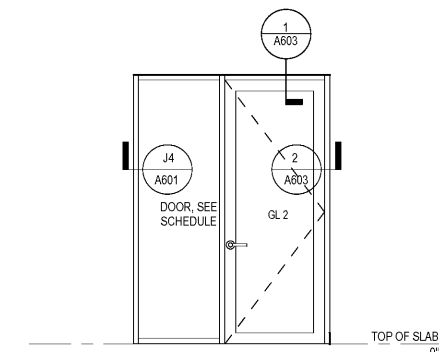

8 ISF1  
A602 SCALE: 3/8" = 1'-0"

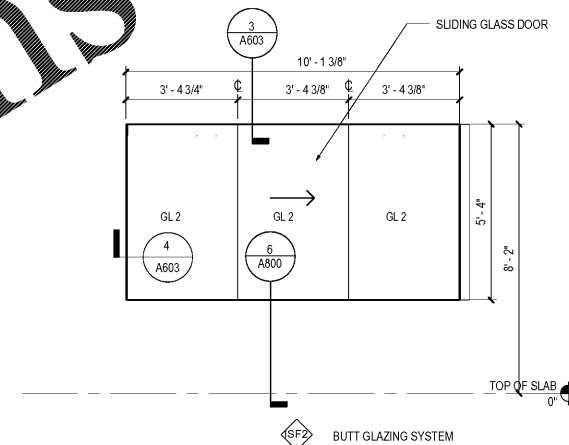

9 ISF2  
A602 SCALE: 3/8" = 1'-0"

GLAZING LEGEND

- GL 1 LOW E COATED, CLEAR INSULATED GLASS
- GL 2 MONOLITHIC GLASS ULTRACLEAR

Revision	Date	Description

Town of James Island  
**TOWN HALL**

1122 Dills Bluff Road  
Charleston, SC 29412

Project Number:	15102
Checked By:	JGC
Drawn By:	EGB
Date:	04/03/17
Scale:	

**A602**  
CW AND SF  
SCHEDULE AND  
TYPES

Order Plans @